



YUH CHERN

Forging The Future

[www.challengehardware.com.tw](http://www.challengehardware.com.tw)

**Industrial  
Conveyor Chains**  
Steel Cable Protector Chains





ZC

ZUH CHERN

# ABOUT YUH CHERN

In 1979, Yuh Chern Manufacturing Co., Ltd. was established in Taichung City, Taiwan.

## Core Business

Since our inception, we have developed a professional hot forging manufacturing service model together with experienced stamping and machining competitiveness that focuses on standardized and customized products in the field of conveyor chains and related products.

## Product Range

1 Enclosed Track  
Conveyor Chains

2 Drop Forged Rivetless  
Conveyor Chains

3 Industrial  
Conveyor Chains

## The Endless Pursuit for Perfection

Along with business growth, we had not only upgraded manufacturing facilities but also implemented the following management systems:

- ISO 9001 (Quality Management)
- ERP (Enterprise Resource Planning)
- SFT (Shop Floor Tracking)
- PLM (Product Lifecycle Management)
- APS (Advanced Planning and Scheduling)

## Experience Makes the Difference

Over the decades, our research and development team has accumulated valuable expertise in product development in order to provide customers with professional technical advice in the early stages of their product development. The efforts include material analysis, structure design and surface treatment. By utilizing software such as AutoCAD, Solidworks, Autodesk Inventor, SolidCAM, Cimatron CAD/CAM and Geomagic Design, we are capable of processing more than a hundred development cases per year. This has allowed us to provide increased product developing efficiency and helped customers to shorten the products TTM (time to market) period.



### Company Quality Policy

Customer Satisfaction & Continuous Improvement



### Company Vision

To further our knowledge and skill capabilities as a service provider in the technical fields of forging, stamping and machining.



### Company Mission

Through quality services and innovation, provide our customers with the most trusted and technologically advanced products.

# INDUSTRIAL CONVEYOR CHAINS

---

## OEM & ODM Custom-Made Chains

Yuh Chern is consistently working with OEM/ODM customers to develop and manufacturer a variety of customized chain products; please refer to the following photos of our OEM/ODM chain products. If you are interested in any of our chain products or OEM/ODM services, please contact one of our sales staff for further assistance.



## Steel Cable Protector Chains

The flexible cable protector chain, also known as Drag Chain or Cable Carrier, are flexible structures consisting of links designed to surround and guide a variety of cables and hoses on automated equipment and machinery. These include flexible electrical cables, hydraulic and pneumatic hoses. The chain will reduce cable and hose wear, prevent entanglement and increase facility safety.

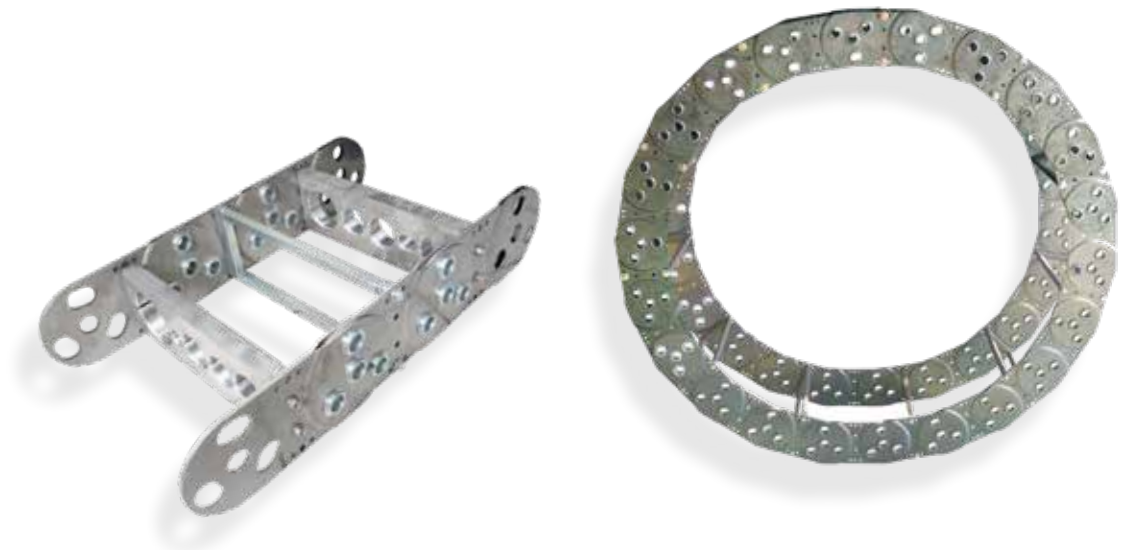
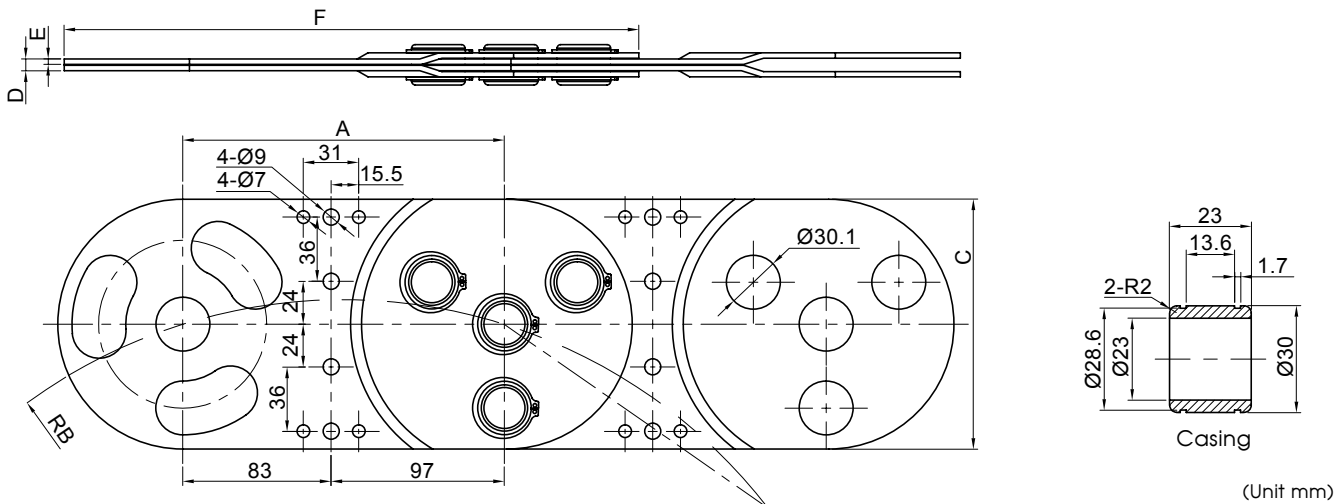

▲ The illustrated images are application examples.

Item NO.	Description	A	B	C	D	E	F	Material	Surface Finishing
501360504004	P180 Cable Protector Chain Link (R300)	180	300	140	6.6	3	321.5	SS400	Zinc Plated
501360504003	P180 Cable Protector Chain Link (R320)	180	320	140	6.6	3	321.5	SS400	Zinc Plated
501360504005	P180 Cable Protector Chain Link (R400)	180	400	140	6.6	3	321.5	SS400	Zinc Plated
501360504001	P180 Cable Protector Chain Link (R600)	180	600	140	6.6	3	321.5	SS400	Zinc Plated
501360504002	P180 Cable Protector Chain Link (R700)	180	700	140	6.6	3	321.5	SS400	Zinc Plated

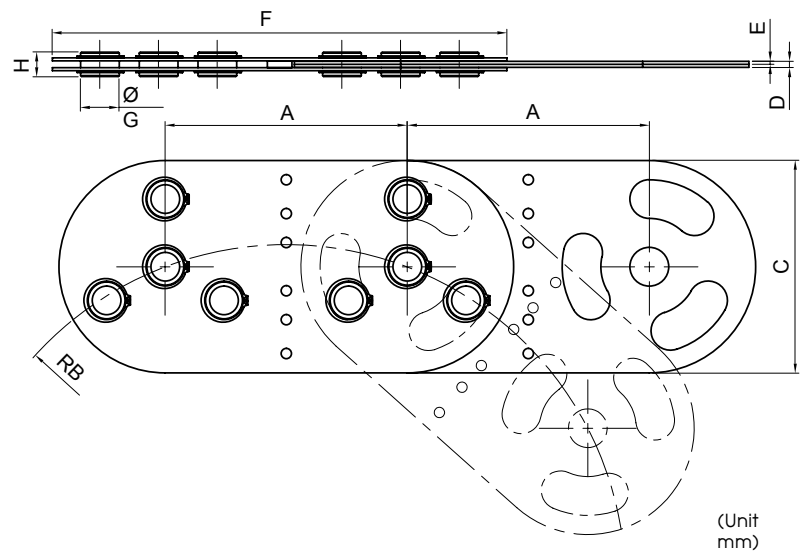

▲ The illustrated images are application examples.

Item NO.	Description	A	B	C	D	E	F	G	H	Material	Surface Finishing
50610440003	P250 Cable Protector Chain Link (R350)	250	350	220	6.4	3.2	469.5	39.95	26	SS400	Zinc Plated
50610440004	P250 Cable Protector Chain Link (R600)	250	600	220	6.4	3.2	469.5	39.95	26	SS400	Zinc Plated



YUH CHERN MANUFACTURING CO., LTD.

No.336, Dingtai Rd., Wufeng Dist., Taichung City 413, Taiwan (R.O.C.)

Tel : +886-4-2330-7323 Fax : +886-4-2332-5258

Email : [service@challengehardware.com.tw](mailto:service@challengehardware.com.tw)