



YUH CHERN

Forging The Future

www.challengehardware.com.tw

Industrial Conveyor Chains

RF-Type Industrial Conveyor Chains





YJC

YUJIH CHERN

ABOUT YUH CHERN

In 1979, Yuh Chern Manufacturing Co., Ltd. was established in Taichung City, Taiwan.

Core Business

Since our inception, we have developed a professional hot forging manufacturing service model together with experienced stamping and machining competitiveness that focuses on standardized and customized products in the field of conveyor chains and related products.

Product Range

1 Enclosed Track
Conveyor Chains

2 Drop Forged Rivetless
Conveyor Chains

3 Industrial
Conveyor Chains

The Endless Pursuit for Perfection

Along with business growth, we had not only upgraded manufacturing facilities but also implemented the following management systems:

- ISO 9001 (Quality Management)
- ERP (Enterprise Resource Planning)
- SFT (Shop Floor Tracking)
- PLM (Product Lifecycle Management)
- APS (Advanced Planning and Scheduling)

Experience Makes the Difference

Over the decades, our research and development team has accumulated valuable expertise in product development in order to provide customers with professional technical advice in the early stages of their product development. The efforts include material analysis, structure design and surface treatment. By utilizing software such as AutoCAD, Solidworks, Autodesk Inventor, SolidCAM, Cimatron CAD/CAM and Geomagic Design, we are capable of processing more than a hundred development cases per year. This has allowed us to provide increased product developing efficiency and helped customers to shorten the products TTM (time to market) period.



Company Quality Policy

Customer Satisfaction & Continuous Improvement



Company Vision

To further our knowledge and skill capabilities as a service provider in the technical fields of forging, stamping and machining.



Company Mission

Through quality services and innovation, provide our customers with the most trusted and technologically advanced products.

INDUSTRIAL CONVEYOR CHAINS

OEM & ODM Custom-Made Chains

Yuh Chern is consistently working with OEM/ODM customers to develop and manufacturer a variety of customized chain products; please refer to the following photos of our OEM/ODM chain products. If you are interested in any of our chain products or OEM/ODM services, please contact one of our sales staff for further assistance.



RF Type Industrial Conveyor Chains

The RF Type Industrial Conveyor Chain is an evolution of the RS Roller Chain. The unique design includes the incorporation of flat attachments.

There are three types of rollers: the S-type, R-type, and F-type. The chain attachments are K-type, A-type, G-type, SK-type and SA-type. All of the optional attachments are stamped or welded onto the chain. This chain is used in extreme working environments, such as wastewater and sludge treatment plants, cement or powder conveyor lines. With our precision stamping and proper heat treatments, we are capable of producing this type of chain for any type of conveyor equipment.

• RF2120S-6LEP Conveyor Chain

Item NO. 501350901001

Material	SAE1045
Surface Finishing	Anti-Rust Oil
Min. Ultimate Tensile Strength (kgf)	16500

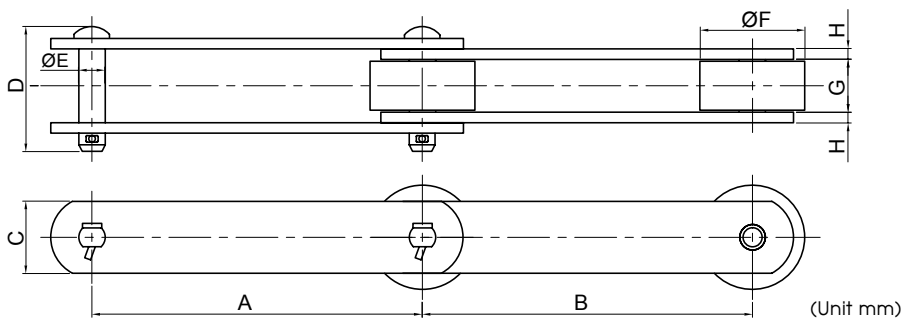
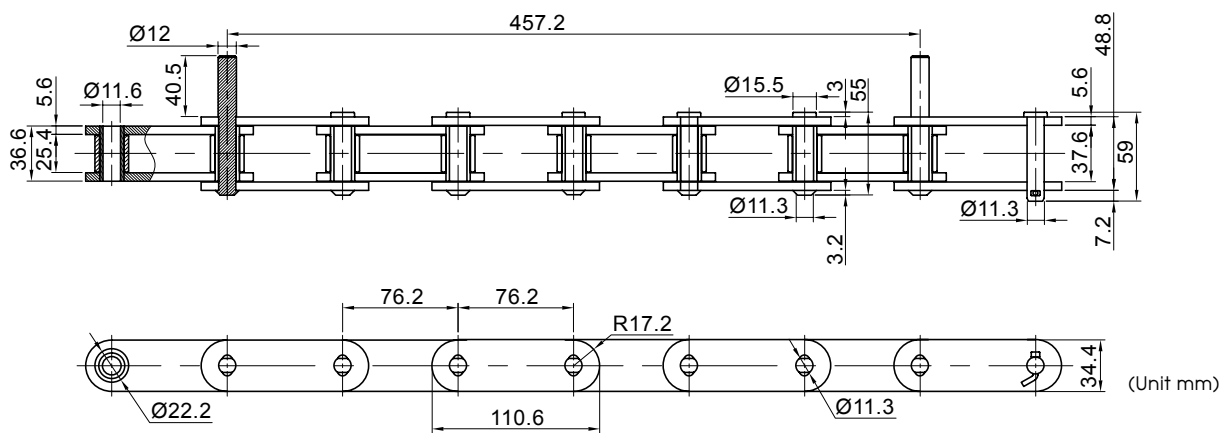

Item NO.	Description	A	B	C	D	E	F	G	H	Material	Surface Finishing	Min. Ultimate Tensile Strength (kgf)
5014240002	RF03100R Conveyor Chain	100	100	22	38	8	31.8	16.1	3.2	SAE1045	Anti-Rust Oil	3000
5014240003	RF05100R Conveyor Chain	100	100	32	53.5	11.3	40	22	4.5	SAE1045	Anti-Rust Oil	7000
5014240004	RF05150R Conveyor Chain	150	150	32	53.5	11.3	40	22	4.5	SAE1045	Anti-Rust Oil	7000
5014340002	RF10150R Conveyor Chain	150	150	38.1	69	14.5	50.8	30	6.3	SAE1045	Anti-Rust Oil	11500

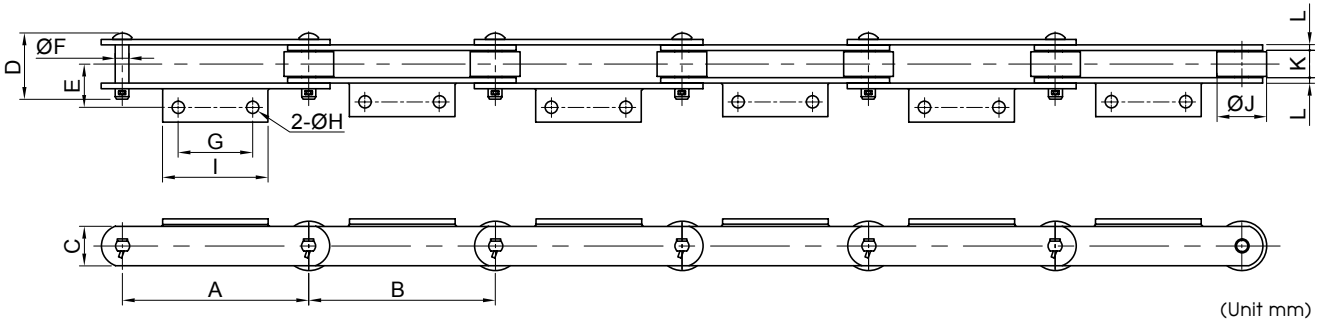

(Unit mm)

Item NO.	Description	A	B	C	D	E	F	G	H	I	J	K	L	Material	Surface Finishing	Min. Ultimate Tensile Strength (kgf)
5014240001	RF6205F-5LA2 Conveyor Chain with A2 Attachment	152.4	152.4	44.5	83.5	60	15.9	60	15	100	57.2	37.1	7.9	SAE1045	Anti-Rust Oil	19000
5014240005	RF05150R-1LA2 Conveyor Chain with A2 Attachment	150	150	32	53.5	35	11.3	60	10	85	40	22	4.5	SAE1045	Anti-Rust Oil	7000

• **HR35088F-GA4 Lift Chain**

Item NO. 50620080004

Material | SCM440/420
 Surface Finishing | Anti-Rust Oil
 Min. Ultimate Tensile Strength (kgf) | 32000

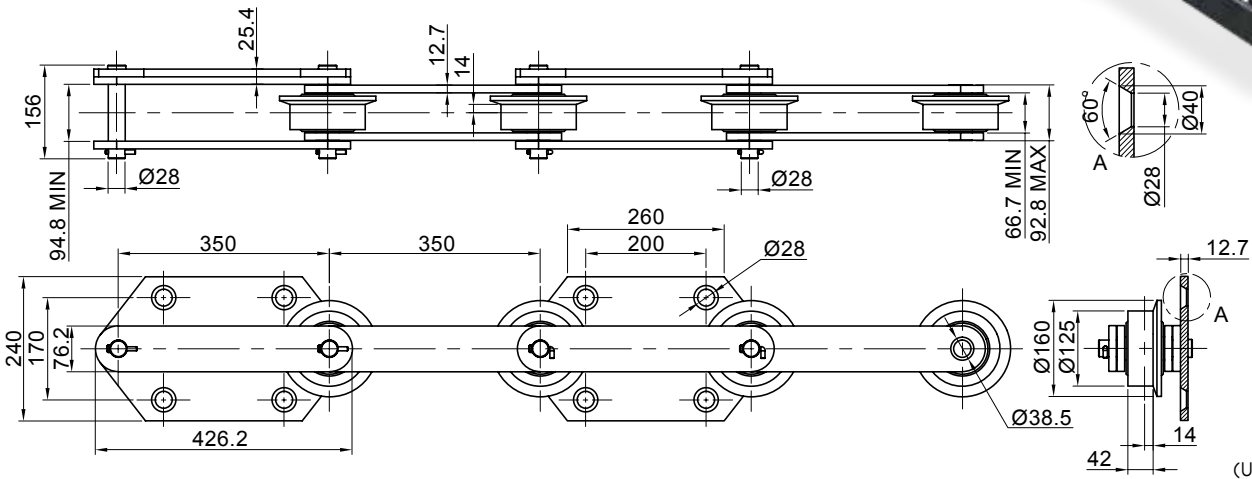

(Unit mm)



YUH CHERN MANUFACTURING CO., LTD.

No.336, Dingtai Rd., Wufeng Dist., Taichung City 413, Taiwan (R.O.C.)

Tel : +886-4-2330-7323 Fax : +886-4-2332-5258

Email : service@challengehardware.com.tw